

## DETECTION OF ADSORBED OR CONDENSED WATER FILMS WITH THE AID OF THERMAL OSCILLATIONS

Th. Gast and R. Talebi  
 Institut für Meß- und Regelungstechnik, Technische Universität Berlin

### SUMMARY

Water is distinguished by an especially high value of specific heat capacity. If water vapour is adsorbed by or condensed on the surface of a metal foil, a noticeable increase in apparent heat capacity of the substrate occurs. This contribution can be quantitatively determined by means of thermal oscillations.

### INTRODUCTION

In order to determine the specific heat capacity of a liquid or disperse matter, the method of thermal oscillations can be applied. The sample is spread over the surface of a metal substrate, which is heated by an alternating current of low frequency. The resulting sinusoidal temperature fluctuations of substrate and layer show a phase lag with regard to heating power. This lag depends on the total heat capacity of foil and film and on the heat transmission from their surfaces to the environment. By means of an automatically compensating circuit, a direct signal for the heat capacity can be extracted from the thermal fluctuations of the foil.

### MEASURING ARRANGEMENT AND RESULTS

#### Fundamental set up

A platinum band with a thickness of 2,5  $\mu\text{m}$  fulfills functions as substrate, heater and temperature sensor. As can be learned from the block diagram in Fig. 1, a signal generator feeds a current  $I$  with a frequency of 0,2 - 3 Hz through the foil, which has the resistance  $R$ .

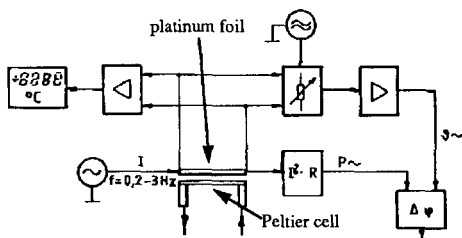

**Fig.1** Circuit for the detection of condensation and sorption of water vapour by thermal fluctuations

A signal which represents the power  $P$  acting, is formed according to the equation ( 1 )

$$P = I^2 R \quad (1)$$

and fed to a phasemeter together with a signal for the temperature fluctuations. The second signal is obtained by measuring  $R$  with the aid of a bridge circuit.

If the foil is cooled beneath the dew point by a Peltier Cell , water is condensed on its surface. Since the specific heat capacity of the condensed layer is higher than that of platinum by a factor of 30 , the phase difference between the temperature of the foil and the heating power is noticeably increased . This change can be utilized for dew point measurement but the system is sufficiently sensitive to detect sorption layers also.( ref. 1 )

### Analytical determination of the temperature difference $\Delta\theta$ and the phase shift $\Delta\phi$

Assuming that the heat flow to the clamps of the foil is negligible , the heat generated in the foil (  $\dot{Q}_J$  ) is transferred to the environment by convection and radiation or stored in the foil on account of its heat capacity (  $\dot{Q}_{st}$  )

$$\begin{aligned} P = I^2 * R = \dot{Q}_J &= \dot{Q}_K + \dot{Q}_r + \dot{Q}_{st} \\ &= \alpha_K l b \Delta\theta + \epsilon \sigma ( T_{pt}^4 - T_u^4 ) l b + C \frac{d}{dt} \Delta\theta \end{aligned} \quad (2)$$

where  $\alpha_K$  is the coefficient of heat transmission by convection,  $l, b$  are length and width of the foil,  $\epsilon$  is the emissivity of platinum and of the irradiated surrounding surface ,  $\sigma$  the Stefan Boltzmann-constant,  $T$  the absolute temperature ,  $C$  the heat capacity of the foil. It is favorable to define a coefficient of heat transfer also for radiation

$$\alpha_r = \frac{\sigma \epsilon ( T_{pt}^4 - T_u^4 )}{( T_{pt} - T_u )} = \sigma \epsilon ( T_{pt} + T_u ) ( T_{pt}^2 + T_u^2 ) \quad (3)$$

for small temperature differences  $( T_{pt} - T_u ) \ll T_u$

$$\alpha_r = 4 T_{pt}^3 \quad (4)$$

$\alpha_K$  and  $\alpha_r$  are summarized

$$\alpha = \alpha_K + \alpha_r \quad (5)$$

and inserted in ( 2 )

$$I^2 R = \alpha b l \Delta\theta + C \frac{d \Delta\theta}{dt} = P \quad (6)$$

In order to effect a strictly sinusoidal course of  $P$ , the heating current is multiplied with the voltage drop at the foil and the product is controlled to follow exactly the signal from a low frequency sine wave generator .A positive bias equal to the amplitude of the signal is applied because negative values of power must be excluded.

On the right hand side of equation ( 6 ) the power  $P$  is written  $P = P_0 ( 1 + \sin \omega t )$  that is

$$I^2 R = \alpha b l \Delta\theta + C \frac{d \Delta\theta}{dt} = P_0 ( 1 + \sin \omega t ) \quad (7)$$

The result of this first order differential equation is

$$\Delta\theta = P_0 \sqrt{\frac{1}{(\alpha b l)^2 + (\omega C)^2}} \sin\left(\omega t - \arctan\frac{C}{\alpha b l}\right) + \frac{P_0}{\alpha b l} \quad (8)$$

As can be seen, the temperature lags behind the impressed power by the angle

$$\Delta\phi = \arctan\frac{C}{\alpha b l} \quad (9)$$

### Design of the Sensor

The following aspects have been considered: Two foils are provided constituting one half of a Wheatstone bridge, one is heated with fluctuating power, the other serves as reference. Length of the stripes is about 20 mm, width about 5 mm, thickness, as mentioned above, 2,5  $\mu\text{m}$ . The platinum foils had to be stretched above the Peltier cell without direct mechanical contact. Otherwise a thermal short circuit may occur and also an electric one, if the surface of the Peltier cell is metallic. The construction can be seen from Fig. 2. The foils are fixed at one end by two insulated clamps, at the other end by a common spring loaded clamp which is moveable in a guide.

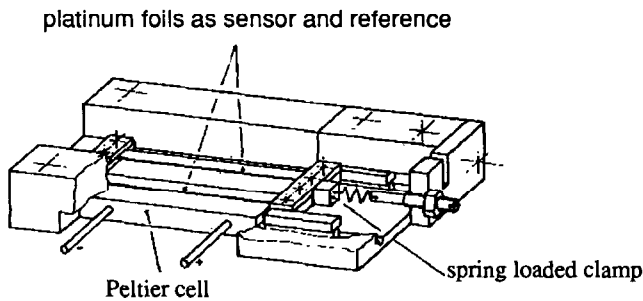

Fig. 2 Construction of the sensor

### Measurement of the Sinusoidal Temperature Difference

The sinusoidal temperature difference has an amplitude of 1 K and is measured with the aid of the platinum foil as resistance thermometer in a bridge. A carrier frequency of 2,5 kHz is used. If an accuracy of 1% is aspired, a very small change in resistance has to be detected. The resistance of the foils being 0,35  $\Omega$  at 25°C, it corresponds to 10<sup>-5</sup>  $\Omega$ . Measurement of such small variations is liable to considerable errors on account of leads between the resistors and contact resistances at the binding posts. Using a Kelvin bridge, this errors could be sufficiently reduced. To keep the contact resistances small, the clamps are gold plated.

### Low-noise amplification for small signals

As the resistance of the foil is  $R = 0,35 \Omega$  at 25 °C, its value will be changed according to the relation

$$R = R_0 (1 + a \Delta\theta) \quad (10)$$

with  $a = 3,91 \cdot 10^{-3} / \text{K}$  by  $\Delta R = 1,4 \cdot 10^{-3} \Omega$  if the temperature changes by 1K.

The measuring current being 50 mA , the resulting voltage at the bridge diagonal is

$$\Delta U = \frac{1}{2} \Delta R I = \frac{1}{2} 1.4 \cdot 10^{-3} \Omega \cdot 50 \cdot 10^{-3} A = 35 \mu V$$

As preliminary studies of phase measurement have shown , this small signal must be sufficient-ly amplified to get a signal of 500 mV<sub>pp</sub>, necessary for the following processing.

Essential in the selection of electronic components for the signal processing is that besides the thermal noise of the signal in connection with the source resistance, instrumental amplifier noise has to be considered. The lower the signal to noise ratio , the higher the expenditure for the noise suppressing filters. Fig 3 shows the Thomson bridge with a special lownoise-instrumental amplifier for very weak signals.

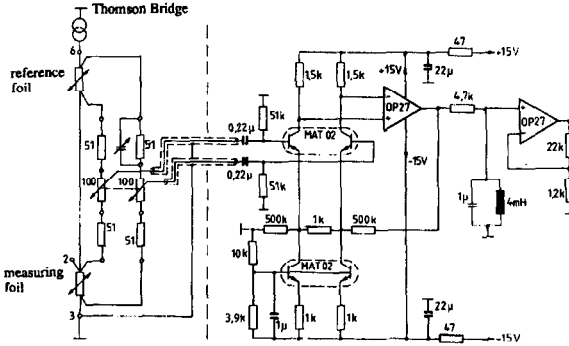

**Fig. 3** Circuit for the measurement of temperature fluctuations

The instrumental amplifier developed by the PMI-company (50) has by proper dimensioning and careful selection of the decisive components proven suitable in this respect. The noise power density of its input transistor pair MAT 02 is only 0,5 nV/√Hz.( ref. 2 )

Analog measurement of phase

In order to utilize the phase lag  $\Delta\phi$  as signal for the variation of heat capacity or as controlled variable , a circuit for analog phase measurement has been set up.

As can be seen in Fig.4 the sinusoidal signal corresponding to the difference of temperatures of the foils is transformed into a square wave signal by a comparator and successively into a trapezoid signal by an integrator. The sinusoidal signal corresponding to the power is transformed into short pulses which trigger the sample and hold circuit for the trapezoid signal. It follows from the lower part of Fig. 4 that the sampling rate is one per period.

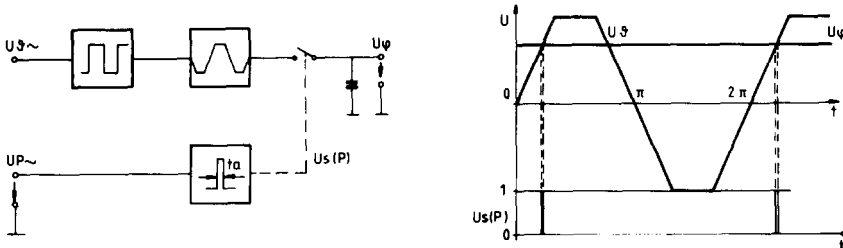

**Fig 4** Phase measurement with sample and hold unit

a) Functional schematic

b) Variation in time

This kind of phase measurement has the following advantages:

- the output voltage is a linear function of the phase by means of the sine-trapezoid conversion.
- the sensitivity of the phase measurement can be easily adjusted by the steepness of the trapezoid curve.

### Detection of condensed water by phase measurement

An experiment for the demonstration of dew formation on the sensor foil has been carried out in the following manner: The sensor was inserted in a measuring chamber, where a relative humidity of 75% prevailed, due to a surface of salt solution with a concentration of 36%. The platinum foils were cooled beneath the dew point with the aid of the Peltier cell.

Fig.5 shows the recorded course of  $\Delta\phi$

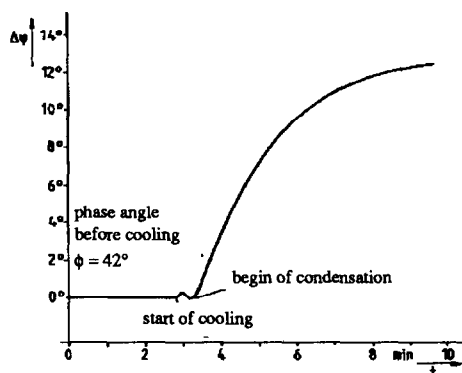

**Fig. 5** Variation in phase by condensation of water vapour on the foil

Beginning with a constant value, the phase shows a small increase immediately after the start of cooling and a subsequent return to the initial value, followed by a steep rise which is caused by the formation of a condensed layer on the surface of the platinum foil. This proves the suitability of the detection method. A disadvantage is to be seen in the fact, that the measuring effect is superimposed by physical influences which interfere with quantitative determination.

### Detection of adsorbed water on a platinum foil

The sensor was put into a chamber with a constant humidity of 75%, the observed phase signal at first raised steeply and gradually attained a final value. Later, the humidity was very quickly reduced to 35% as measured by a reference instrument by opening the chamber to the environment without changing the temperature. The variation of the phase signal was recorded. As can be seen in Fig.6 the final value is reached in about one minute. In this experiment, only the variation of heat capacity is effective, heat transmission between foil and environment is not changed. The variation of phase is exclusively due to sorption.

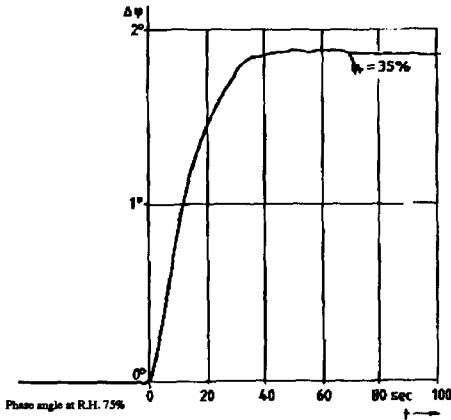

Fig. 6 Variation in phase by a sudden change in relative humidity

Direct measurement of heat capacity

According to the equation (9) not only the heat capacity, but also the heat transmission affects the phase. In order to eliminate the influence of the uncertain heat transmission, an electric signal for the heat capacity is extracted. The method has been developed by Jacobs (ref. 3). Between temperature and power, the relationship

$$\Delta\theta = \frac{P}{\alpha A + \varphi \omega C} \tag{11}$$

exists, as derived from equation (7) with  $A = 1 b$ .

As Fig. 7a shows there is a phase difference of  $90^\circ$  between the capacitive heat flux  $P_C$  and the dissipative heat flux  $P$ .

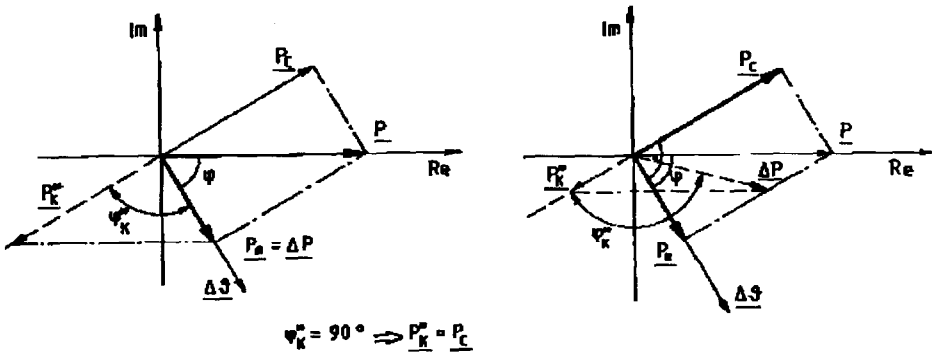

Fig. 7 Vector diagram of power P in two states of compensation

Differentiating the sinusoidal temperature fluctuation  $\Delta\theta$  with regard to time and subsequent rotation by  $180^\circ$  yields the vector  $P_k^*$  which leads  $P_C$  by  $180^\circ$ .

$$-P_k^* = \frac{d \Delta \theta}{dt} = j \omega K^* \Delta \theta = \frac{j \omega K^* P}{(\alpha A + j \omega C)} \quad (12)$$

$K^*$  has been introduced as a real variable. Subtraction of  $P_k$  from the total alternating power  $P$  results in the power difference  $\Delta P$  which encloses with  $P_k^*$  the angle  $\phi_k^*$ .

$$\Delta P = P - P_k^* = P - K^* j \omega \Delta \theta = \left[ 1 - \frac{\phi \omega K^*}{\alpha A + j \omega C} \right] P \quad (13)$$

$$\Delta P = \left[ \frac{\alpha A}{\alpha A + j \omega C} + \frac{j \omega (C - K^*)}{\alpha A + j \omega C} \right] P \quad (14)$$

If  $K^*$  is varied until  $\phi_k^* = 90^\circ$ , the second term of equation (14) disappears, and  $P_k^* = P_C$  as well as  $K^* = C$  are valid, thus  $K^*$  is equal to the heat capacity  $C$ . As can be seen in Fig. 8 where the variables  $\theta$  and  $P$  are represented by signal voltages, the voltage  $U_k^*$  which stands for  $K^*$  is controlled in such a way that the output of the phase sensitive rectifier is zero. This means, that the phase difference between  $\Delta P = P - P_k$  and  $P_k$  is  $90^\circ$  and  $U_k^*$  is therefore a direct measure of heat capacity. The measurement is independent of heat transmission.

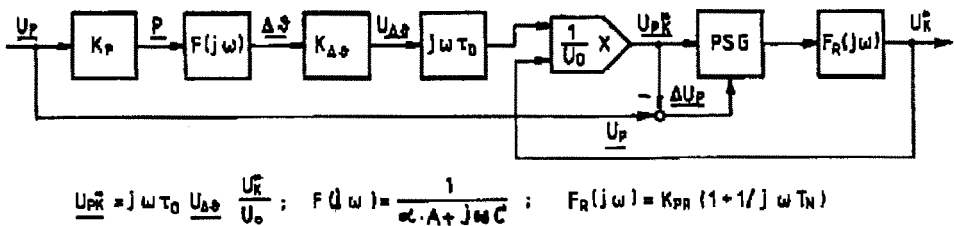

Fig. 8 Block diagram for the measurement of heat capacity

### The adsorption isotherm of platinum

Strömberger (ref. 4) has measured the sorption of water vapour on platinum foil with the aid of an electromagnetic microbalance. The macroscopic surface was  $365 \text{ mm}^2$ , the thickness  $10 \text{ }\mu\text{m}$ . After annealing at bright red-heat in vacuum, the foil was suspended from the balance beam and weighed with an uncertainty of  $\pm 4,5 \text{ ng}$ . The desired values of relative humidity were adjusted by mixtures of water and sulfuric acid. From the increase in weight by sorption, the thickness of a corresponding layer of water was calculated. Fig. 9 shows a sorption isotherm measured in this way. Assuming a molecular diameter of  $2,6 \text{ \AA}$ , the number of molecular layers adsorbed was nearly two for a relative humidity of  $1,06 \%$  and about 200 for  $99\%$  as interpolated from the curve.

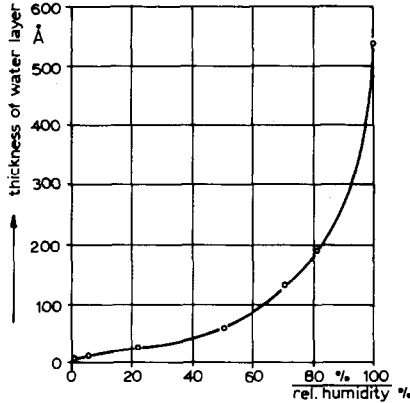

Fig. 9 Sorption isotherm of platinum as measured by Strömberger

The variation of heat capacity by sorption of water vapour

The direct measurement of heat capacity by thermal fluctuations presents a possibility to measure the sorption of water vapour on the platinum foil continuously. The changes in heat capacity can be calculated from the corresponding variations of the signal  $U_k^*$  at the output of the controller in Fig.8 . According to the equation

$$C = \frac{U_k^*}{K_c} \tag{15}$$

the constant  $K_c$  is obtained from the known heat capacity of the platinum foil and the value  $U_k^*$  in the initial state of the foil.

Fig.10 shows two curves which were taken in this manner . Curve a resembles the sorption isotherm measured by Kochsiek ( ref. 5 ) and is known as isotherm type III after Brunauer ( ref. 6 ).

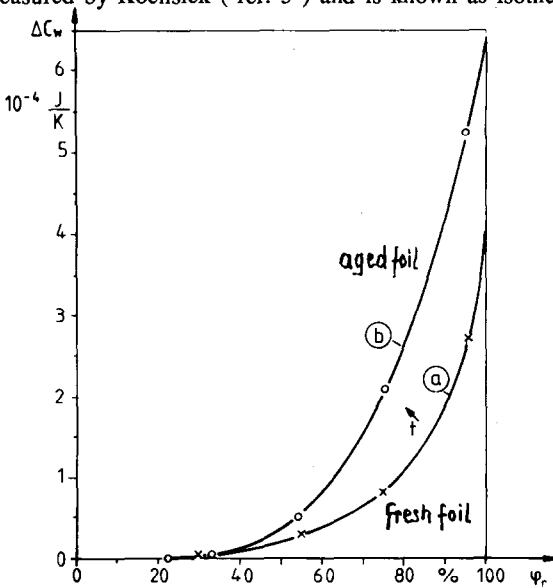

Fig. 10 Heat capacity as function of relative humidity



Below 20% relative humidity, no variation in heat capacity could be detected. The foil shows a hydrophobic behaviour. Between 20 % and 40% relative humidity the heat capacity changes but slightly. Repetition of the measurement after a considerable number of sorption cycles yields the curve b which is noticeably steeper than a. The cause of this alteration is not yet clarified. It may be attributed to contamination of the surface.

## Literature

- ( 1 ) R. Talebi-Daryyani, Luftfeuchtemessung mit Hilfe von Wärmeschwingungen, Dissertation T.U. Berlin 1987, D3.
- ( 2 ) Application information Fa. PMI,1984.
- ( 3 ) H. Jakobs, Ein Beitrag zur gleichzeitigen Bestimmung von Wärmekapazität und Masse sehr kleiner Stoffproben mit Hilfe von thermischen und mechanischen Schwingungen, Dissertation T.U. Berlin 1984 , D 83.
- ( 4 ) R. Strömberger, Adsorptionsmessung mit einer neuverbreiteten Mikrowaage, Königl. Svensk Akademiens Handlingar, Vol 6 Nr. 2, Stockholm 1928.
- ( 5 ) M. Kochsiek , Measurement of water adsorption layers on metal surfaces, Metrologie 18 (1982) 153-159.
- ( 6 ) St. Brunauer, The adsorption of gases and vapours , Physical Adsorption, Vol. I , Princeton University , 1945.